

PM Stepping Motor with GearBox

PMステッピングモータ ギヤボックス付き

■ 参考特性 Reference Characteristics

駆動電圧 Drive Voltage	12 [V]
電流／相 Current / Phase	300 [mA] (Peak)
励磁方式 Drive Method	2-2相 2-2 phase
駆動方式 Drive Circuit	バイポーラチョッパー BIPOLAR CHOPPER
巻線抵抗／相 Resistance / Phase	10 [Ω]
駆動 IC Driver IC	LB1847
絶縁抵抗 Insulation Resistance	100 M [Ω] Min. at DC500 [V]
絶縁耐圧 Dielectric Strength	AC 500 [V] 1 [min]
絶縁種 Class of Insulation	Class E (リード線を除く Except lead wire)
温度上昇 Temperature Rise	65 [°C] MAX
使用周辺温度 Ambient Temperature Range	-10 [°C] ~ +50 [°C]
ラジアルガタ Radial Play	0.03 [mm] * フランジ端面から 6 [mm] 6 [mm] from flange
スラストガタ Axial Play	0.25 [mm]



■ トルク特性 Torque Characteristics

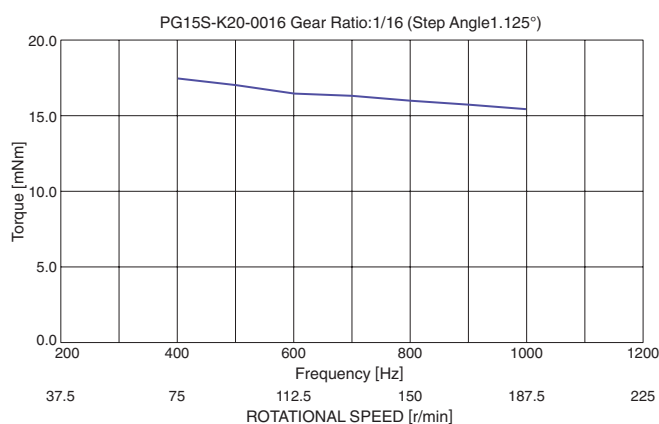

■ 用途 Application

光学機器：プロジェクター、監視カメラ
Optical Equipment：Projector / Security Camera

医療機器：血液分析装置、チューブポンプ
Medical Equipment：Blood Analyzer / Tube Pump

産業機器：流動制御バルブ、アンテナ調整機
Industrial Equipment：Flow Control Valves / Antenna Adjustment Device

電動工具：ドリル、ドライバー
Power Tools：Drills / Drivers

■ 外観図 Outline

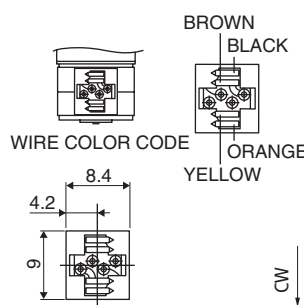
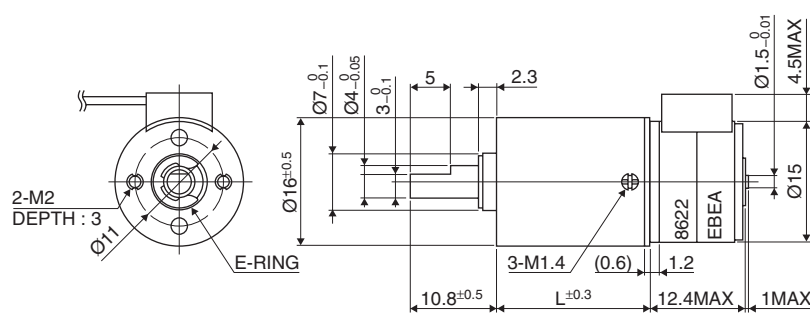

WIRE COLOR	MOTOR
BLACK	A1
BROWN	A3
ORANGE	B1
YELLOW	B3

WIRE COLOR CODE

COLOR	BLACK	BROWN	ORANGE	YELLOW
STEP				
1	-	+	+	-
2	-	+	-	+
3	+	-	-	+
4	+	-	+	-

SWITCHING SEQUENCE (VIEWD FROM MOUNTING SURFACE)

■ ラインナップ Lineup

型式 Model	ステップ角 Step Angle [deg]	減速比 Gear Ratio [1 : X]	推奨定格トルク Rated Torque [mNm (gf cm)]	推奨瞬間最大トルク Maximum Instantaneous Torque [mNm (gf cm)]	ギヤヘッド長 L Gearhead length L [mm]
PG15S-K20-0004	4.500	1 : 4	49 (500)	73.5 (750)	11.4
PG15S-K20-0016	1.125	1 : 16	73.5 (750)	110.3 (1125)	15.5
PG15S-K20-0024	0.750	1 : 24			
PG15S-K20-0064	0.281	1 : 64	98 (1000)	147 (1500)	18.6
PG15S-K20-0096	0.187	1 : 96			
PG15S-K20-0144	0.125	1 : 144			